

Operating Instructions

Profinet Robacta CTC
Profinet Robacta TX
Profinet Robacta TX 10i
Profinet Robacta TX/i TWIN

DE | Bedienungsanleitung

EN-US | Operating instructions



Inhaltsverzeichnis

Allgemeines	4
Inhalt dieses Dokumentes.....	4
Eigenschaften der Datenübertragung.....	4
Konfigurationsparameter.....	4
Geräte-Stammdatei für Feldbuskoppler BK9103.....	4
Adresseinstellungen am Feldbus-Koppler mittels DIP-Schalter.....	5
Technische Daten.....	5
Sicherheit.....	5
Anschlüsse und Steckerbelegungen.....	6
Anschlüsse für die Roboter-Steuerung an Robacta FB 8I_8O (Robacta CTC).....	6
Anschlüsse für die Roboter-Steuerung an der Geräte-Außenseite von Robacta TX, TX 10i, TX/i TWIN.....	6
Steckerbelegung für Anschluss Profinet RJ 45 AIDA	7
Steckerbelegung für Anschluss Versorgung +24 V AIDA	7
Getrennte / gemeinsame 24 V Spannungsversorgung.....	8
Getrennte 24 V Spannungsversorgung	8
Gemeinsame 24 V Spannungsversorgung extern	8
Gemeinsame 24 V Spannungsversorgung intern.....	8
Ein- und Ausgangssignale Robacta CTC.....	10
Anordnung der Feldbus-Klemmen (optionale Konfiguration)	10
Eingangssignale (von CTC zum Roboter).....	10
Ausgangssignale (vom Roboter zu CTC).....	10
Zusätzlicher Funktionsumfang von Robacta FB 8I_8O Profinet	11
Ein- und Ausgangssignale Robacta TX.....	18
Anordnung der Feldbus-Klemmen.....	18
Eingangssignale (von der Brennerkörper-Wechselstation zum Roboter)	18
Ausgangssignale (vom Roboter zur Brennerkörper-Wechselstation).....	19
Ein- und Ausgangssignale Robacta TX 10i.....	21
Anordnung der Feldbus-Klemmen.....	21
Eingangssignale (von der Brennerkörper-Wechselstation zum Roboter)	21
Ausgangssignale (vom Roboter zur Brennerkörper-Wechselstation).....	22
Ein- und Ausgangssignale Robacta TX/i TWIN.....	24
Anordnung der Feldbus-Klemmen.....	24
Eingangssignale (von der Brennerkörper-Wechselstation zum Roboter)	24
Ausgangssignale (vom Roboter zur Brennerkörper-Wechselstation).....	25
Fehlerdiagnose, Fehlerbehebung.....	26
Allgemeines	26
Feldbus-Status LEDs.....	26
Betriebszustand LEDs.....	28
Versorgungsanzeige LEDs	30
Diagnose Ethernet/Switch LEDs.....	30

Allgemeines

- Inhalt dieses Dokumentes** Dieses Dokument enthält Profinet Konfigurations- und Anwendungs-Informationen für
- Das Roboterinterface Robacta FB 8I_8O (dient beispielsweise als Roboterinterface für Robacta CTC)
 - Die Profinet-Schnittstellen von Robacta TX, TX 10i, TW/i TWIN
-

Eigenschaften der Datenübertragung	Übertragungstechnik:	Ethernet
	Netzwerk Topologie:	Stern, Linie
	Medium:	Twisted-Pair-Kabel
	Übertragungsrate:	100 Mbit/s, Full-Duplex-Mode
	Busanschluss:	Profinet RJ 45 AIDA

Konfigurationsparameter

Konfigurationsparameter für Robacta TX, Robacta TX 10i, Robacta TX/i TWIN	
Vendor ID:	01B0 _{hex}
Device ID:	0201 _{hex}
Station Type:	fronius-tx-4-100-707

Konfigurationsparameter für alle weiteren Geräte	
Vendor ID:	0120 _{hex}
Device ID:	02328 _{hex}
Station Type:	bk9103

- Geräte-Stammdatei für Feldbuskoppler BK9103** Jedem Teilnehmer in einem Profinet-Netzwerk ist eine Geräte-Stammdatei zugeordnet. Die Geräte-Stammdatei enthält alle Informationen über den Teilnehmer und ist für die Netzwerk-Konfiguration erforderlich.
- Die Geräte-Stammdatei für Robacta TX, Robacta TX 10i, Robacta TX/i TWIN ist zu finden unter: www.fronius.com
 - Die Geräte-Stammdatei für alle weiteren Geräte ist zu finden unter: www.beckhoff.com

Adresseinstellungen am Feldbus-Koppler mittels DIP-Schalter

Die DIP-Schalter am Feldbus-Koppler dienen zur Auswahl von verschiedenen Adressierungsmöglichkeiten und des Profinet-Namens. Profinet-konform verhält sich das Gerät, wenn

- die DIP-Schalter 1-8 in Stellung - OFF - geschaltet sind
- die DIP-Schalter 9 und 10 in Stellung - ON - geschaltet sind

Alle anderen Modi sind als Option möglich.

HINWEIS!

Um sicherzustellen, dass der Feldbus-Koppler nach einer Änderung die Adresseinstellungen übernimmt, den Feldbus-Koppler neu starten.

Technische Daten

Die technischen Daten des Feldbus-Kopplers sind zu finden unter:
www.beckhoff.com

Sicherheit

WARNUNG!

Gefahr durch Fehlbedienung und fehlerhaft durchgeführte Arbeiten.

Schwere Personen- und Sachschäden können die Folge sein.

- ▶ Alle in diesem Dokument beschriebenen Arbeiten und Funktionen dürfen nur von technisch geschultem Fachpersonal ausgeführt werden.
- ▶ Dieses Dokument vollständig lesen und verstehen.
- ▶ Sämtliche Sicherheitsvorschriften und Benutzerdokumentationen dieses Gerätes und aller Systemkomponenten lesen und verstehen.

WARNUNG!

Gefahr durch elektrischen Strom.

Schwere Personen- und Sachschäden können die Folge sein.

- ▶ Vor Beginn der Arbeiten alle beteiligten Geräte und Komponenten ausschalten und vom Stromnetz trennen.
- ▶ Alle beteiligten Geräte und Komponenten gegen Wiedereinschalten sichern.

WARNUNG!

Gefahr durch unplanmäßige Signalübertragung.

Schwere Personen- und Sachschäden können die Folge sein.

- ▶ Über das Interface keine sicherheitsrelevanten Signale übertragen.

Anschlüsse und Steckerbelegungen

Anschlüsse für die Roboter-Steuerung an Robacta FB 8I_80 (Robacta CTC)

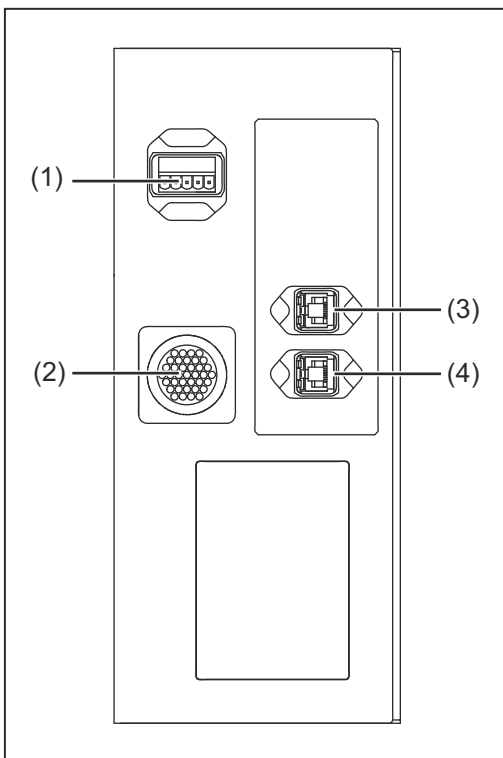

Anschlüsse an Robacta FB 8I_80

- (1) Anschluss Versorgung +24 V AIDA**
zur Versorgung des Feldbus-Kopplers und der Feldbus-Klemmen

- (2) Anschluss-Stecker Standard I/O 1**
zur Verbindung mit Robacta CTC

- (3) Anschluss Profinet RJ 45 AIDA**

- (4) Anschluss Profinet RJ 45 AIDA**

Anschlüsse für die Roboter-Steuerung an der Geräte-Außenseite von Robacta TX, TX 10i, TX/i TWIN

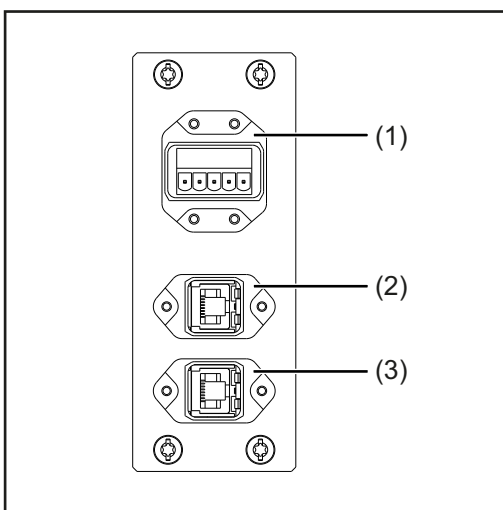

- (1) Anschluss Versorgung +24 V AIDA**
zur Versorgung des Feldbus-Kopplers und der Feldbus-Klemmen

- (2) Anschluss Profinet RJ 45 AIDA**

- (3) Anschluss Profinet RJ 45 AIDA**

**Steckerbelegung
für Anschluss
Profinet RJ 45
AIDA**

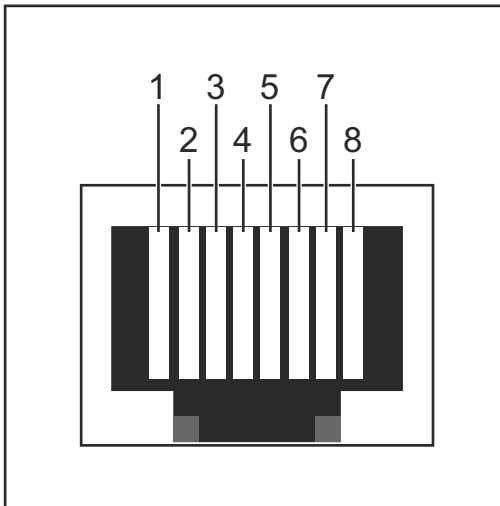

Pin-Belegung RJ 45 ProfiNet Anschluss

1	TX+
2	TX-
3	RX+
6	RX-
4,5,7, 8	Normalerweise nicht verwendet; um die Signalfullständigkeit sicherzustellen, sind diese Pins miteinander verbunden und enden über einen Filterkreis am Schutzleiter (PE).

**Steckerbelegung
für Anschluss
Versorgung +24
V AIDA**

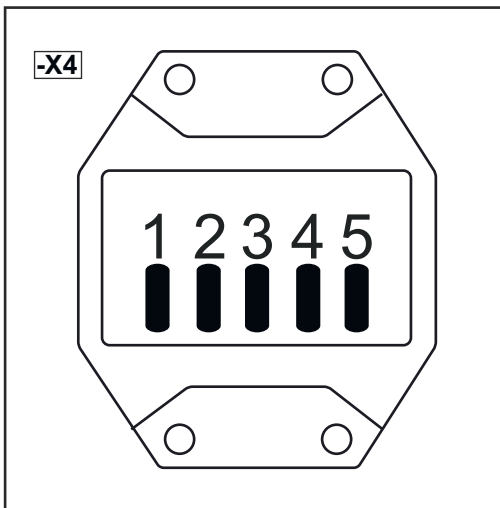

Pin	Belegung
1	+24 V Spannungsversorgung für den Feldbus-Koppler
2	0 V Spannungsversorgung für den Feldbus-Koppler
3	+24 V Spannungsversorgung für die I/O-Klemmen
4	0 V Spannungsversorgung für die I/O-Klemmen
5	-

Getrennte / gemeinsame 24 V Spannungsversorgung

Getrennte 24 V Spannungsversorgung

Das Roboterinterface Robacta FB 8I_80 ist serienmäßig für eine getrennte 24 V Versorgung von Feldbus-Buskoppler und I/O-Klemmen ausgelegt. Hierfür sind zwei separate 24 V Stromkreise erforderlich, das Roboterinterface muss nicht geöffnet werden.

Vorgehensweise:

- 1 Stromkreis 1 an den Pins 1 (-X4:1) und 2 (-X4:2) anlegen
 - 2 Stromkreis 2 an den Pins 2 (-X4:3) und 4 (-X4:4) anlegen
-

Gemeinsame 24 V Spannungsversorgung extern

Alternativ können Feldbus-Buskoppler und I/O-Klemmen auch gemeinsam über einen 24 V Stromkreis versorgt werden.

Bei der externen gemeinsamen Spannungsversorgung muss das Roboterinterface nicht geöffnet werden.

Vorgehensweise:

- 1 Am mitgelieferten Stecker Pin 1 (-X4:1) und Pin 3 (-X4:3) mittels Bügel überbrücken
 - 2 Am mitgelieferten Stecker Pin 2 (-X4:2) und Pin 4 (-X4:4) mittels Bügel überbrücken
 - 3 Stromkreis an den Pins 1 (-X4:1) und 2 (-X4:2) anlegen
-

Gemeinsame 24 V Spannungsversorgung intern

Die zweite Alternative für eine gemeinsame Spannungsversorgung mit einem 24 V Stromkreis ist die interne Spannungsversorgung.

Vorgehensweise:



- 1 Das Roboterinterface Robacta FB 8I_80 öffnen
- 2 Beim Feldbus-Koppler den Stecker von 24V/OV trennen

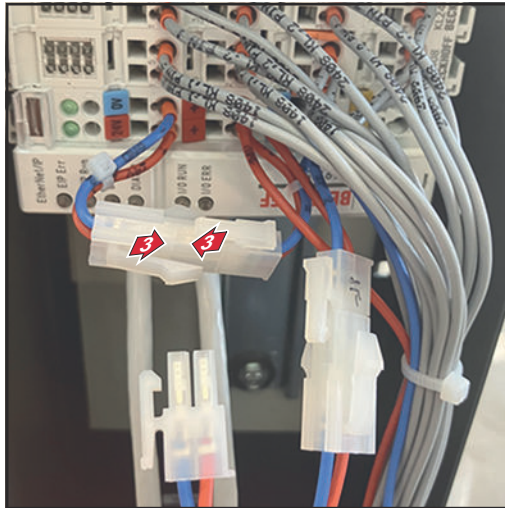

- 3 Kabel 24V/0V vom Feldbus-Koppler mit dem freien Kabelende von +/- zusammenstecken
- 4 Das Roboterinterface Robacta FB 8I_8O schließen
- 5 Stromkreis an den Pins 3 (-X4:3) und 4 (-X4:4) anlegen

Ein- und Ausgangssignale Robacta CTC

Anordnung der Feldbus-Klemmen (optionale Konfiguration)

Folgend die werksseitige Anordnung der Feldbus-Klemmen:

BK 9103	KL1408	KL2408	KL1408 (OPT// Robacta FB 16L_160 4,101,345,CK)	KL2408 (OPT// Robacta FB 16L_160 4,101,345,CK)	KL9010
---------	--------	--------	--	--	--------

Es besteht die Möglichkeit, die zwei nachfolgend angeführten Feldbus-Klemmen in das Roboterinterface einzubauen. Dadurch kann zusätzlich zu Robacta CTC noch ein Schweißbrenner-Reinigungsgerät an das Interface angeschlossen werden. Für nähere Informationen hierfür siehe Abschnitt **Zusätzlicher Funktionsumfang von Robacta FB 8I_80 Profinet** ab Seite **11**.

Optionale Feldbus-Klemmen

- KL1408 und
- KL2408

Beide Klemmen sind Bestandteil der Option 4,101,345,CK.

Eingangssignale (von CTC zum Roboter)

Eingang	Signal	Bereich	Aktivität
E01	TLC	-	High
E02	VA	-	High
E03	LS	-	High
E04	Reserve	-	-
E05	SS1	-	High
E06	SS2	-	High
E07	1A	-	High
E08	Reserve	-	-

Die Beschreibungen der Signale sind in der Bedienungsanleitung von Robacta CTC zu finden.

Ausgangssignale (vom Roboter zu CTC)

Ausgang	Signal	Bereich	Aktivität
A01	MC	-	High
A02	FWD	-	High
A03	REV	-	High
A04	TL	-	High
A05	MO	-	High
A06	M1	-	High

Ausgang	Signal	Bereich	Aktivität
A07	Reserve	-	-
A08	Reserve	-	-

Die Beschreibungen der Signale sind in der Bedienungsanleitung von Robacta CTC zu finden.

Zusätzlicher Funktionsumfang von Robacta FB 8I_80 Profinet

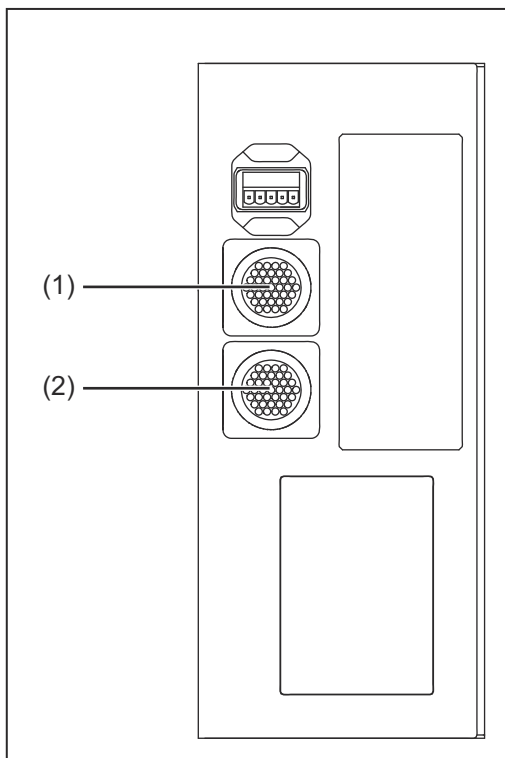

Anschlüsse an Robacta FB 8I_80 Profinet

(1) Anschluss-Stecker Standard I/O 1

dieser Stecker befindet sich immer am Roboterinterface und dient zur Verbindung von Robacta CTC mit dem Roboterinterface

(2) Anschluss-Stecker Standard I/O 2

dieser Stecker wird mit der Option 4,101,345,CK in das Roboterinterface eingebaut.

Mit diesem Stecker können zusätzlich zu Robacta CTC noch Schweißbrenner-Reinigungsgeräte am Roboterinterface angeschlossen werden. Für die Verbindung der Schweißbrenner-Reinigungsgeräte mit dem Roboterinterface ausschließlich die bei Fronius erhältlichen Kabelbäume verwenden.

Eingangssignale

für Robacta Reamer V Easy, Robacta Reamer V Easy Han6P J, Robacta Reamer Alu Edition, Robacta Reamer Alu 3000upm, Robacta Reamer Bürstenkopf Alu, Robacta Reamer Twin:

Eingang (Vom Feldbus-Koppler zum Anschluss-Stecker Standard I/O 2)	Pin am Anschluss-Stecker Standard I/O 2	Signal	Aktivität
E09	11	Gasdüse frei	High
E10	12	Reserve	-
E11	13	Reserve	-
E12	14	Reserve	-
E13	15	Reserve	-
E14	16	Reserve	-

Eingang (Vom Feldbus-Kopp- ler zum Anschluss- Stecker Standard I/O 2)	Pin am An- schluss-Ste- cker Standard I/O 2	Signal	Aktivität
E15	17	Reserve	-
E16	18	Reserve	-

**Ausgangssignale für
Robacta Reamer V Easy, Robacta Reamer V Easy Han6P J, Robacta Reamer Alu
Edition, Robacta Reamer Alu 3000upm, Robacta Reamer Bürstenkopf Alu, Ro-
bacta Reamer Twin:**

Ausgang (Vom Anschluss- Stecker Standard I/O 2 zum Feldbus- koppler)	Pin am An- schluss-Ste- cker Standard I/O 2	Signal	Aktivität
+24 V	1	-	-
GND	2	-	-
A09	3	Reinigung starten	High
A10	4	Reserve	-
A11	5	Reserve	-
A12	6	Reserve	-
A13	7	Reserve	-
A14	8	Reserve	-
A15	9	Reserve	-
A16	10	Reserve	-

Eingangssignale für Reamer Braze+:

Eingang (Vom Feldbus-Kopp- ler zum Anschluss- Stecker Standard I/O 2)	Pin am An- schluss-Ste- cker Standard I/O 2	Signal	Aktivität
E09	11	Reinigungsbereit	High
E10	12	Reserve	-
E11	13	Reserve	-
E12	14	Reserve	-
E13	15	Reserve	-
E14	16	Reserve	-
E15	17	Reserve	-
E16	18	Reserve	-

Ausgangssignale für Robacta Reamer Braze+:

Ausgang (Vom Anschluss- Stecker Standard I/O 2 zum Feldbus- koppler)	Pin am An- schluss-Ste- cker Standard I/O 2	Signal	Aktivität
+24 V	1	-	-
GND	2	-	-
A09	3	Reinigungsmotor starten	High
A10	4	Reinigungskopf justieren	High
A11	5	Reserve	-
A12	6	Reserve	-
A13	7	Reserve	-
A14	8	Reserve	-
A15	9	Reserve	-
A16	10	Reserve	-

Eingangssignale für Reamer Robacta Reamer V:

Eingang (Vom Feldbus-Kopp- ler zum Anschluss- Stecker Standard I/O 2)	Pin am An- schluss-Ste- cker Standard I/O 2	Signal	Aktivität
E09	11	Gasdüse frei	High
E10	12	Gasdüse gespannt	High
E11	13	Reinigungsmotor dreht	High
E12	14	Trennmittel-Stand in Ord- nung	High
E13	15	Reinigungsmotor unten	High
E14	16	Reinigungsmotor oben	High
E15	17	Drahtabschneider offen	High
E16	18	Drahtabschneider ge- schlossen	High

Ausgangssignale für Reamer Robacta Reamer V:

Ausgang (Vom Anschluss- Stecker Standard I/O 2 zum Feldbus- koppler)	Pin am An- schluss-Ste- cker Standard I/O 2	Signal	Aktivität
+24 V	1	-	-
GND	2	-	-
A09	3	Gasdüse spannen / Reini- gungsmotor ein	High
A10	4	Trennmittel einsprühen	High

Ausgang (Vom Anschluss- Stecker Standard I/O 2 zum Feldbus- koppler)	Pin am An- schluss-Ste- cker Standard I/O 2	Signal	Aktivität
A11	5	Drahtelektrode abschnei- den	High
A12	6	Reinigungsmotor auf	High
A13	7	Optionaler GND für Sen- soren	High
A14	8	Reserve	-
A15	9	Reserve	-
A16	10	Reserve	-

Eingangssignale für Robacta Reamer V Twin:

Eingang (Vom Feldbus-Kopp- ler zum Anschluss- Stecker Standard I/O 2)	Pin am An- schluss-Ste- cker Standard I/O 2	Signal	Aktivität
E09	11	Gasdüse frei	High
E10	12	Gasdüse gespannt	High
E11	13	Reserve	-
E12	14	Trennmittel-Stand in Ord- nung	High
E13	15	Reinigungsmotor unten	High
E14	16	Reinigungsmotor oben	High
E15	17	Schwenk-Vorrichtung links	High
E16	18	Schwenk-Vorrichtung rechts	High

Ausgangssignale für Robacta Reamer V Twin:

Ausgang (Vom Anschluss- Stecker Standard I/O 2 zum Feldbus- koppler)	Pin am An- schluss-Ste- cker Standard I/O 2	Signal	Aktivität
+24 V	1	-	-
GND	2	-	-
A09	3	Gasdüse spannen / Reini- gungsmotor ein	High
A10	4	Trennmittel einsprühen	High
A11	5	Drahtelektrode abschnei- den	High
A12	6	Reinigungsmotor auf	High

Ausgang (Vom Anschluss- Stecker Standard I/O 2 zum Feldbus- koppler)	Pin am An- schluss-Ste- cker Standard I/O 2	Signal	Aktivität
A13	7	Schwenk-Vorrichtung nach links	High
A14	8	Schwenk-Vorrichtung nach rechts	High
A15	9	Reserve	-
A16	10	Reserve	-

Eingangssignale für Robacta Reamer V 70 Han12P:

Eingang (Vom Feldbus-Kopp- ler zum Anschluss- Stecker Standard I/O 2)	Pin am An- schluss-Ste- cker Standard I/O 2	Signal	Aktivität
E09	11	Gasdüse frei	High
E10	12	Reserve	-
E11	13	Reserve	-
E12	14	Reserve	-
E13	15	Reserve	-
E14	16	Reinigungsmotor oben	High
E15	17	Reserve	-
E16	18	Reserve	-

Ausgangssignale für Robacta Reamer V 70 Han12P:

Ausgang (Vom Anschluss- Stecker Standard I/O 2 zum Feldbus- koppler)	Pin am An- schluss-Ste- cker Standard I/O 2	Signal	Aktivität
+24 V	1	-	-
GND	2	-	-
A09	3	Reinigung starten	High
A10	4	Trennmittel einsprühen	High
A11	5	Drahtelektrode abschnei- den	High
A12	6	GND für Sensoren	High
A13	7	Reserve	-
A14	8	Reserve	-
A15	9	Reserve	-
A16	10	Reserve	-

Eingangssignale für Robacta Reamer V Comfort:

Eingang (Vom Feldbus-Koppler zum Anschluss-Stecker Standard I/O 2)	Pin am Anschluss-Stecker Standard I/O 2	Signal	Aktivität
E09	11	Gasdüse frei	High
E10	12	Ausgangssignal Sensor	High
E11	13	Ausgangssignal Sensor	High
E12	14	Trennmittel-Stand in Ordnung	-
E13	15	Reserve	-
E14	16	Reinigungsmotor oben	High
E15	17	Reserve	-
E16	18	Reserve	-

Ausgangssignale für Robacta Reamer V Comfort:

Ausgang (Vom Anschluss-Stecker Standard I/O 2 zum Feldbuskoppler)	Pin am Anschluss-Stecker Standard I/O 2	Signal	Aktivität
+24 V	1	-	-
GND	2	-	-
A09	3	Reinigung starten	High
A10	4	Trennmittel einsprühen	High
A11	5	Drahtelektrode abschneiden	High
A12	6	Ausgangssignal Aktor	High
A13	7	GND für die Sensoren	High
A14	8	Reserve	-
A15	9	Reserve	-
A16	10	Reserve	-

Eingangssignale für Robacta TC 1000, Robacta TC 2000:

Eingang (Vom Feldbus-Koppler zum Anschluss-Stecker Standard I/O 2)	Pin am Anschluss-Stecker Standard I/O 2	Signal	Aktivität
E09	11	Ready	High
E10	12	Fluid Level Control	High
E11	13	Cleaning Error	High
E12	14	Reserve	-
E13	15	Reserve	-
E14	16	Reserve	-

Eingang (Vom Feldbus-Koppler zum Anschluss-Stecker Standard I/O 2)	Pin am Anschluss-Stecker Standard I/O 2	Signal	Aktivität
E15	17	Reserve	-
E16	18	Reserve	-

Ausgangssignale für Robacta TC 1000, Robacta TC 2000:

Ausgang (Vom Anschluss-Stecker Standard I/O 2 zum Feldbus-koppler)	Pin am Anschluss-Stecker Standard I/O 2	Signal	Aktivität
+24 V	1	-	-
GND	2	-	-
A09	3	Cleaning Start	High
A10	4	Spray In	High
A11	5	Wire Cutter	High
A12	6	Quick Stop	High
A13	7	Reserve	-
A14	8	Reserve	-
A15	9	Reserve	-
A16	10	Reserve	-

Ein- und Ausgangssignale Robacta TX

Anordnung der Feldbus-Klemmen

Folgend die werksseitige Anordnung der Feldbus-Klemmen:

BK 9103 Fronius	KL1408	KL1408	KL1408	KL2408	KL2612	KL9010
-----------------	--------	--------	--------	--------	--------	--------

Es besteht die Möglichkeit, weitere Feldbus-Klemmen in ein Roboterinterface einzubauen. Die Anzahl ist jedoch durch die Gehäusegröße limitiert.

HINWEIS!

Beim Einbau weiterer Feldbus-Klemmen ändert sich das Prozessdatenbild.

Eingangssignale (von der Brennerkörper-Wechselstation zum Roboter)

Eingang	Signal	Bereich	Aktivität
E01	Brennerkörper-Sensor 1	-	High
E02	Brennerkörper-Sensor 2	-	High
E03	Brennerkörper-Sensor 3	-	High
E04	Brennerkörper-Sensor 4	-	High
E05	Brennerkörper-Sensor 5	-	High
E06	Brennerkörper-Sensor 6	-	High
E07	Brennerkörper-Sensor 7	-	High
E08	Brennerkörper-Sensor 8	-	High
E09	Brennerkörper-Sensor 9	-	High
E10	Brennerkörper-Sensor 10	-	High
E11	Signal Drahtsensor	-	High
E12	Signal Druckschalter	-	High
E13	Gasdüse frei (bei Robacta Reamer V) TC Ready (bei Robacta TC)	-	High
E14	Gasdüse frei (bei Robacta Reamer V Easy) Reinigungsmotor unten (bei Robacta Reamer Bürstenkopf Alu)	-	High
E15	Reinigungsmotor dreht (bei Robacta Reamer V)	-	High

Eingang	Signal	Bereich	Aktivität
E16	Trennmittel Füllstand in Ordnung (bei Robacta Reamer V)	-	High
E17	Reinigungsmotor unten (bei Robacta Reamer V) Cleaning Error (bei Robacta TC)	-	High
E18	Reinigungsmotor oben (bei Robacta Reamer V)	-	High
E19	Drahtabschneider geschlossen	-	High
E20	Drahtabschneider offen	-	High
E21	Signal Rutsche	-	High
E22	'C-Sens. 4' Signal 1	-	High
E23	Sensor 1 Abdeckung Robacta TX	-	High
E24	Sensor 2 Abdeckung Robacta TX	-	High

Die Beschreibungen der Signale sind in der Bedienungsanleitung von Robacta TX zu finden.

Ausgangssignale (vom Roboter zur Brennerkörper- Wechselstation)

Ausgang	Signal	Bereich	Aktivität
A01	Gasdüse spannen und Reinigungsmotor ein (bei Robacta Reamer V) Reinigung starten (bei Robacta Reamer V Easy und Robacta Reamer Bürstenkopf Alu) Cleaning Start (bei Robacta TC)	-	High
A02	Trennmittel einsprühen (bei Robacta Reamer V)	-	High
A03	Reinigungsmotor auf (bei Robacta Reamer V)	-	High
A04	Drahtelektrode abschneiden	-	High
A05	Ventil 1 Abdeckung Robacta TX	-	High
A06	Ventil 2 Abdeckung Robacta TX	-	High
A07	'C-Act. 3' Signal 1	-	High
A08	Nicht verwendet	-	-
A09	Ventil 1 Brenner wechseln	-	High
A10	Reserve Relais OUT	-	High
A11	Nicht verwendet	-	-
A12	Nicht verwendet	-	-

Ausgang	Signal	Bereich	Aktivität
A13	Nicht verwendet	-	-
A14	Nicht verwendet	-	-
A15	Nicht verwendet	-	-
A16	Nicht verwendet	-	-

Die Beschreibungen der Signale sind in der Bedienungsanleitung von Robacta TX zu finden.

Ein- und Ausgangssignale Robacta TX 10i

Anordnung der Feldbus-Klemmen

Folgend die werksseitige Anordnung der Feldbus-Klemmen:

BK 9103 Fronius	KL1408	KL1408	KL1408	KL2408	KL2612	KL9010
-----------------	--------	--------	--------	--------	--------	--------

Es besteht die Möglichkeit, weitere Feldbus-Klemmen in ein Roboterinterface einzubauen. Die Anzahl ist jedoch durch die Gehäusegröße limitiert.

HINWEIS!

Beim Einbau weiterer Feldbus-Klemmen ändert sich das Prozessdatenbild.

Eingangssignale (von der Brennerkörper-Wechselstation zum Roboter)

Eingang	Signal	Bereich	Aktivität
E01	Brennerkörper-Sensor 1	-	High
E02	Brennerkörper-Sensor 2	-	High
E03	Brennerkörper-Sensor 3	-	High
E04	Brennerkörper-Sensor 4	-	High
E05	Brennerkörper-Sensor 5	-	High
E06	Brennerkörper-Sensor 6	-	High
E07	Brennerkörper-Sensor 7	-	High
E08	Brennerkörper-Sensor 8	-	High
E09	Brennerkörper-Sensor 9	-	High
E10	Brennerkörper-Sensor 10	-	High
E11	Signal Drahtsensor	-	High
E12	Nicht verwendet	-	-
E13	Gasdüse frei (bei Robacta Reamer V) TC Ready (bei Robacta TC)	-	High
E14	Gasdüse frei (bei Robacta Reamer V Easy) Reinigungsmotor unten (bei Robacta Reamer Bürstenkopf Alu)	-	High
E15	Reinigungsmotor dreht (bei Robacta Reamer V)	-	High

Eingang	Signal	Bereich	Aktivität
E16	Trennmittel Füllstand in Ordnung (bei Robacta Reamer V)	-	High
E17	Reinigungsmotor unten (bei Robacta Reamer V) Cleaning Error (bei Robacta TC)	-	High
E18	Reinigungsmotor oben (bei Robacta Reamer V)	-	High
E19	Drahtabschneider geschlossen	-	High
E20	Drahtabschneider offen	-	High
E21	Signal Rutsche	-	High
E22	'C-Sens. 4' Signal 1	-	High
E23	Sensor 1 Abdeckung	-	High
E24	Sensor 2 Abdeckung	-	High

Die Beschreibungen der Signale sind in der Bedienungsanleitung von Robacta TX 10i zu finden.

**Ausgangssignale
(vom Roboter
zur Bren-
nerkörper-
Wechselstation)**

Ausgang	Signal	Bereich	Aktivität
A01	Gasdüse spannen und Reinigungsmotor ein (bei Robacta Reamer V) Reinigung starten (bei Robacta Reamer V Easy und Robacta Reamer Bürstenkopf Alu) Cleaning Start (bei Robacta TC)	-	High
A02	Trennmittel einsprühen (bei Robacta Reamer V)	-	High
A03	Reinigungsmotor auf (bei Robacta Reamer V)	-	High
A04	Drahtelektrode abschneiden	-	High
A05	Ventil 1 Abdeckung Robacta TX	-	High
A06	Ventil 2 Abdeckung Robacta TX	-	High
A07	'C-Act. 3' Signal 1	-	High
A08	Nicht verwendet	-	-
A09	Nicht verwendet	-	-
A10	Reserve Relais OUT	-	High
A11	Nicht verwendet	-	-
A12	Nicht verwendet	-	-

Ausgang	Signal	Bereich	Aktivität
A13	Nicht verwendet	-	-
A14	Nicht verwendet	-	-
A15	Nicht verwendet	-	-
A16	Nicht verwendet	-	-

Die Beschreibungen der Signale sind in der Bedienungsanleitung von Robacta TX 10i zu finden.

Ein- und Ausgangssignale Robacta TX/i TWIN

Anordnung der Feldbus-Klemmen

Folgend die werksseitige Anordnung der Feldbus-Klemmen:

BK 9103 Fronius	KL1408	KL1408	KL1408	KL2408	KL2612	KL9010
-----------------	--------	--------	--------	--------	--------	--------

Es besteht die Möglichkeit, weitere Feldbus-Klemmen in ein Roboterinterface einzubauen. Die Anzahl ist jedoch durch die Gehäusegröße limitiert.

HINWEIS!

Beim Einbau weiterer Feldbus-Klemmen ändert sich das Prozessdatenbild.

Eingangssignale (von der Brennerkörper-Wechselstation zum Roboter)

Eingang	Signal	Bereich	Aktivität
E01	Brennerkörper-Sensor 1	-	High
E02	Brennerkörper-Sensor 2	-	High
E03	Brennerkörper-Sensor 3	-	High
E04	Brennerkörper-Sensor 4	-	High
E05	Brennerkörper-Sensor 5	-	High
E06	Brennerkörper-Sensor 6	-	High
E07	Brennerkörper-Sensor 7	-	High
E08	Brennerkörper-Sensor 8	-	High
E09	Nicht verwendet	-	-
E10	Nicht verwendet	-	-
E11	Signal Drahtsensor	-	High
E12	Nicht verwendet	-	-
E13	Gasdüse frei (bei Robacta Reamer V Twin) TC Ready (bei Robacta TC)	-	High
E14	Nicht verwendet	-	-
E15	Nicht verwendet	-	-
E16	Fluid Level Control (bei Robacta TC)	-	High
E17	Cleaning Error (bei Robacta TC)	-	High
E18	Nicht verwendet	-	-

Eingang	Signal	Bereich	Aktivität
E19	Nicht verwendet	-	-
E20	Nicht verwendet	-	-
E21	Nicht verwendet	-	-
E22	Nicht verwendet	-	-
E23	Sensor 1. Abdeckung Robacta TX	-	High
E24	Sensor 2. Abdeckung Robacta TX	-	High

Die Beschreibungen der Signale sind in der Bedienungsanleitung von Robacta TX/i TWIN zu finden.

**Ausgangssignale
(vom Roboter
zur Bren-
nerkörper-
Wechselstation)**

Ausgang	Signal	Bereich	Aktivität
A01	Reinigung starten (bei Robacta Reamer V Twin) Cleaning Start (bei Robacta TC)	-	High
A02	Spray In (bei Robacta TC)	-	High
A03	Nicht verwendet	-	-
A04	Drahtelektrode abschneiden	-	High
A05	Ventil 1. Abdeckung Robacta TX	-	High
A06	Ventil 2. Abdeckung Robacta TX	-	High
A07	Nicht verwendet	-	-
A08	Nicht verwendet	-	-
A09	Nicht verwendet	-	-
A10	Reserve Relais OUT	-	High
A11	Nicht verwendet	-	-
A12	Nicht verwendet	-	-
A13	Nicht verwendet	-	-
A14	Nicht verwendet	-	-
A15	Nicht verwendet	-	-
A16	Nicht verwendet	-	-

Die Beschreibungen der Signale sind in der Bedienungsanleitung von Robacta TX/i TWIN zu finden.

Fehlerdiagnose, Fehlerbehebung

Allgemeines

⚠ VORSICHT!

Gefahr durch Spannung beim Trennen oder Herstellen der Busklemmen-Verbindungen.

Sachschäden können die Folge sein.

- ▶ Vor dem Trennen oder Herstellen der Busklemmen-Verbindungen die Netzverbindung trennen.

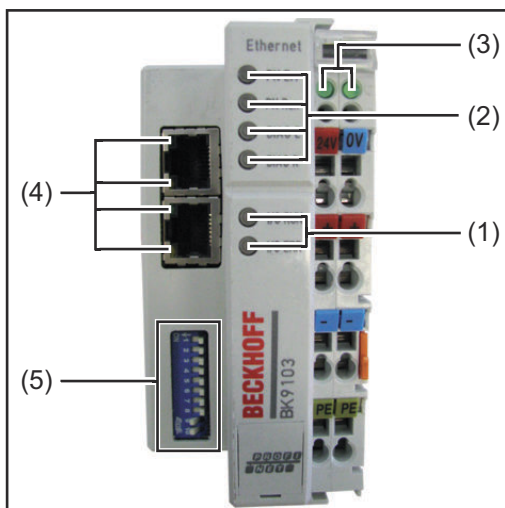

	Beschreibung
(1)	Betriebszustand LEDs (zeigen die Art des Fehlers und die Fehlerstelle an)
(2)	Feldbus-Status LEDs (zeigen die Art des Fehlers und die Fehlerstelle an)
(3)	Versorgungsanzeige LEDs - die linke LED zeigt die Versorgung des Feldbus-Kopplers an - die rechte LED zeigt die Versorgung der Power-Kontakte an
(4)	Diagnose Ethernet/Switch LEDs
(5)	DIP-Schalter

HINWEIS!

Nach der Fehlerbeseitigung beendet der Feldbus-Koppler in manchen Fällen die Blinksequenz nicht.

Durch Aus- und Einschalten der Versorgungsspannung oder durch einen Software Reset den Feldbus-Koppler neu starten.

Feldbus-Status LEDs

Diagnose EtherNet/IP	PN Err (rot)	PN Run (grün)	DIAG E (rot)	DIAG R (grün)
IP Adresse OK	aus	0,5 s	aus	aus
Keine gültige IP Adresse (Dip-Schalter 9 und 10 auf 'On' geschaltet)	0,1 s	aus	aus	aus
Online	aus	an	aus	aus
Offline PLC stopp	aus	0,1 s	aus	aus
Timeout	0,5 s	aus	aus	aus

Diagnose EtherNet/IP	PN Err (rot)	PN Run (grün)	DIAG E (rot)	DIAG R (grün)
Konfigurationsfehler IP Adresse	an	aus	aus	aus
Blinken abwechselnd (ausgelöst durch ein Profinet Tool)	0,5 s	0,5 s	aus	aus

Diagnose Konfiguration	PN Err (rot)	PN Run (grün)	DIAG E (rot)	DIAG R (grün)
OK	aus	aus	aus	an
Falsches Modul	aus	aus	Slot Nummer	1 mal
Fehlendes Modul (physikalisch)	aus	aus	Slot Nummer	2 mal
Fehlendes Modul (in der Konfiguration)	aus	aus	Slot Nummer	3 mal
Kein Profinet-Name vergeben	aus	aus	aus	4 mal
Substitut*	aus	aus	Slot Nummer	5 mal

* Substitut wird bei Modulen gesetzt die falsch konfiguriert, aber trotzdem lauffähig sind (Beispiel: KL22xx2 konfiguriert, an dem Slot steckt aber eine KL2xx4)

HINWEIS!

Treten mehrere Fehler auf, wird immer das letzte fehlerhafte Modul gezeigt.

Beispiel für die Anzeige eines Fehlers

Eine KL2xx4 Klemme ist für den fünften Steckplatz konfiguriert, es sind aber nur 4 Module gesteckt. Der Fehler wird wie folgt angezeigt:

1. LED DIAG E flackert schnell, LED DIAG R ist aus
2. LED DIAG E ist an, LED DIAG R zeigt den Fehler-Code - 2 mal 0,5 Sekunden blinken
3. LED DIAG E und LED DIAG R sind aus
4. LED DIAG E zeigt das Fehlerargument - 5 mal 0,5 Sekunden (hier Slot-Nummer) blinken, LED DIAG R ist aus

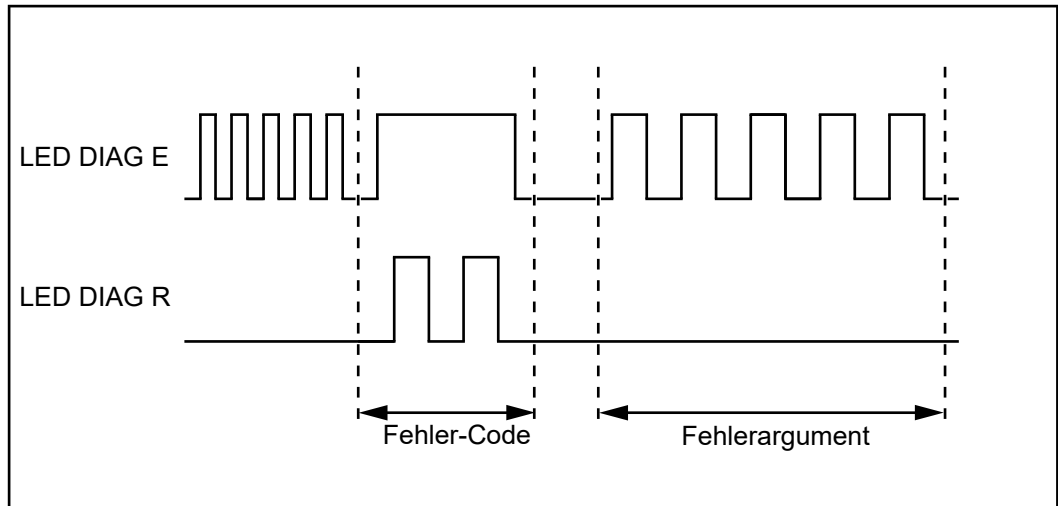

Anzeige eines Fehlers

Betriebszustand LEDs

Fehler-Code	Fehlerargument	Ursache	Behebung
ständiges, konstantes blinken	-	EMV-Probleme	<ul style="list-style-type: none"> - Spannungsversorgung auf Unter- oder Überspannungsspitzen überprüfen - EMV-Maßnahmen ergreifen - Bei einem K-Bus-Fehler, den Fehler durch Aus- und Einschalten des Buskopplers lokalisieren
1 Impuls	0 Impulse	EPROM-Prüfsummenfehler	Herstellereinstellung mit der Konfigurationssoftware KS2000 setzen
	1 Impuls	Überlauf im Code Buffer	Weniger Busklemmen stecken. Bei der programmierten Konfiguration sind zu viele Einträge in der Tabelle
	2 Impulse	Unbekannter Datentyp	Software-Update des Buskopplers
2 Impulse	0 Impulse	Programmierte Konfiguration, falscher Tabelleneintrag	Programmierte Konfiguration auf Richtigkeit überprüfen
	n Impulse (n>0)	Tabellenvergleich (Busklemme n)	Falscher Tabelleneintrag

Fehler-Code	Fehlerargument	Ursache	Behebung
3 Impulse	0 Impulse	K-Bus-Kommandofehler	<ul style="list-style-type: none"> - Keine Busklemme gesteckt - Eine der Busklemmen ist defekt, angehängte Busklemmen halbieren und prüfen, ob der Fehler bei den übrigen Busklemmen noch vorhanden ist. Vorgang wiederholen, bis die defekte Busklemme lokalisiert ist.
4 Impulse	0 Impulse	K-Bus-Datenfehler, Bruchstelle hinter dem Buskoppler	Prüfen, ob die n+1 Busklemme richtig gesteckt ist, gegebenenfalls tauschen
	n Impulse	Bruchstelle hinter Busklemme n	Prüfen, ob die Busklemme 9010 gesteckt ist
5 Impulse	n Impulse	K-Bus-Fehler bei Register-Kommunikation mit Busklemme n	n-te Busklemme tauschen
6 Impulse	0 Impulse	Fehler bei der Initialisierung	Buskoppler tauschen
	1 Impulse	Interner Datenfehler	Buskoppler aus- und einschalten
	4 Impulse	DIP-Schalter für BootP falsch	1-8 in Stellung -Off- stellen
	8 Impulse	Interner Datenfehler	Buskoppler aus- und einschalten
16 Impulse	16 Impulse	Fehler beim IP-Socket	Buskoppler aus- und einschalten
	n Impulse	n-te Busklemme hat das falsche Format	Buskoppler erneut starten. Falls der Fehler erneut auftritt, die Busklemme tauschen.
	n Impulse	Anzahl der Busklemmen stimmt nicht mehr	Buskoppler erneut starten. Falls der Fehler erneut auftritt, Hersteller-einstellung mit der Konfigurationssoftware KS2000 setzen.
	n Impulse	Länge der K-Bus-Daten stimmt nicht mehr	Buskoppler erneut starten. Falls der Fehler erneut auftritt, Hersteller-einstellung mit der Konfigurationssoftware KS2000 setzen.

**Versorgungsan-
zeige LEDs**

LED	Bedeutung
Linke LED aus	Buskoppler hat keine Spannung
Rechte LED aus	Keine Versorgungsspannung + 24 V _{DC} an den Powerkontak- ten angeschlossen

**Diagnose Ether-
net/Switch LEDs**

LED	ein	blinkt	aus
Link/Act	Physikalische Verbindung vor- handen	Kommunikation vorhanden	Keine physikalische Verbindung vorhan- den
10 / 100 MBaud	100 MBaud	-	100 MBaud

Table of contents

General.....	32
Contents of this document.....	32
Data transfer properties.....	32
Configuration parameters.....	32
Device master file for fieldbus coupler BK9103.....	32
Address settings at fieldbus coupler using DIP switches.....	33
Technical data.....	33
Safety.....	33
Connections and connector pin assignments.....	34
Connections for robot controls to Robacta FB 8I_8O (Robacta CTC).....	34
Connections for robot controls on the outside of Robacta TX, TX 10i, TX/i TWIN.....	34
Pin assignment for Profinet connection RJ 45 AIDA.....	35
Pin assignment for supply connection socket +24 V AIDA.....	35
Separate/common 24 V power supply.....	36
Separate 24 V power supply.....	36
Common 24 V external power supply.....	36
Common 24 V internal power supply.....	36
Robacta CTC input and output signals.....	38
Arrangement of the fieldbus terminals (optional configuration).....	38
Input signals (from CTC to robot).....	38
Output signals (from robot to CTC).....	38
Additional scope of functions of Robacta FB 8I_8O Profinet.....	39
Robacta TX input and output signals.....	46
Fieldbus terminal allocation.....	46
Input signals (from the torch body change station to the robot).....	46
Output signals (from the robot to the torch body change station).....	47
Robacta TX 10i input and output signals.....	49
Fieldbus terminal allocation.....	49
Input signals (from the torch body change station to the robot).....	49
Output signals (from the robot to the torch body change station).....	50
Robacta TX /i TWIN input and output signals.....	52
Fieldbus terminal allocation.....	52
Input signals (from the torch body change station to the robot).....	52
Output signals (from the robot to the torch body change station).....	53
Troubleshooting.....	54
General.....	54
Fieldbus status LEDs.....	54
Operating status LEDs.....	56
Supply display LEDs.....	57
Ethernet/Switch diagnostic LEDs.....	58

General

Contents of this document

- This document contains Profinet configuration and application information for
- The robot interface Robacta FB 8I_8O (serves for example as robot interface for Robacta CTC)
 - The Profinet interfaces of Robacta TX, TX 10i, TW/i TWIN
-

Data transfer properties

Transmission technology:	Ethernet
Network topology:	Star, line
Medium:	Twisted pair cable
Transmission rate:	100 Mbit/s, full duplex mode
Bus connection:	Profinet RJ 45 AIDA

Configuration parameters

Configuration parameters for Robacta TX, Robacta TX 10i, Robacta TX/i TWIN	
Vendor ID:	01B0 _{hex}
Device ID:	0201 _{hex}
Station Type:	fronius-tx-4-100-707

Configuration parameters for all other devices	
Vendor ID:	0120 _{hex}
Device ID:	02328 _{hex}
Station Type:	bk9103

Device master file for fieldbus coupler BK9103

A device master file is assigned to every participant in a Profinet network. The device master file contains all information about the participant and is required for the network configuration.

- The device master file for Robacta TX, Robacta TX 10i, Robacta TX/i TWIN can be found at: www.fronius.com
- The device master file for all other devices can be found at: www.beckhoff.com

Address settings at fieldbus coupler using DIP switches

The DIP switches on the fieldbus coupler are used to select different addressing options and the Profinet name. The device conforms to Profinet standards when

- DIP switches 1-8 are set to - OFF -
- DIP switches 9 and 10 are set to - ON -

All other modes are available as options.

NOTE!

You must restart the fieldbus coupler to apply any changes made to fieldbus coupler address settings.

Technical data

The technical data of the fieldbus coupler can be found under:
www.beckhoff.com

Safety **WARNING!****Danger from incorrect operation and work that is not carried out properly.**

This can result in serious personal injury and damage to property.

- ▶ All the work and functions described in this document must only be carried out by technically trained and qualified personnel.
 - ▶ Read and understand this document in full.
 - ▶ Read and understand all safety rules and user documentation for this equipment and all system components.
-

 **WARNING!****Danger from electrical current.**

This can result in serious personal injury and damage to property.

- ▶ Before starting work, switch off all the devices and components involved and disconnect them from the grid.
 - ▶ Secure all devices and components involved so they cannot be switched back on.
-

 **WARNING!****Danger from unplanned signal transmission.**

This can result in serious personal injury and damage to property.

- ▶ Do not transfer safety signals via the interface.
-

Connections and connector pin assignments

Connections for robot controls to Robacta FB 8I_80 (Robacta CTC)

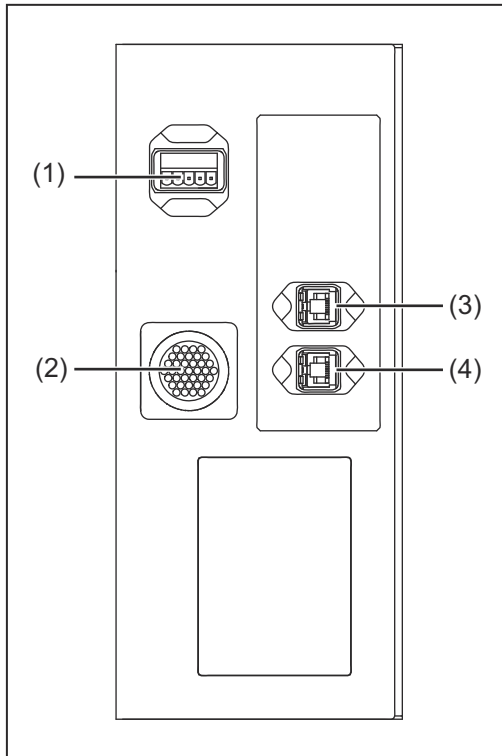

Connections to Robacta FB 8I_80

- (1) **Supply connection +24 V AIDA** for supplying the fieldbus coupler and the fieldbus terminals
- (2) **Standard I/O 1 connecting plug** for connecting to Robacta CTC
- (3) **Profinet connection RJ 45 AI-DA**
- (4) **Profinet connection RJ 45 AI-DA**

Connections for robot controls on the outside of Robacta TX, TX 10i, TX/i TWIN

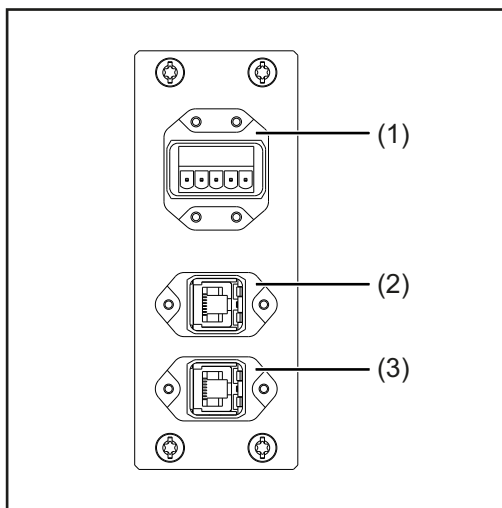

- (1) **Supply connection +24 V AIDA** for supplying the bus coupler and the field bus terminals
- (2) **Profinet connection RJ 45 AI-DA**
- (3) **Profinet connection RJ 45 AI-DA**

Pin assignment for Profinet connection RJ 45 AIDA

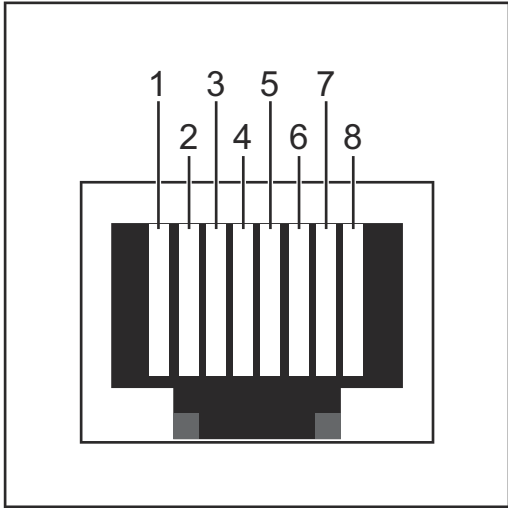

RJ45 connection

1	TX+
2	TX-
3	RX+
6	RX-
4,5,7,8	Not normally used; to ensure signal completeness, these pins must be interconnected and, after passing through a filter circuit, must terminate at the ground conductor (PE).

Pin assignment for supply connection socket +24 V AIDA

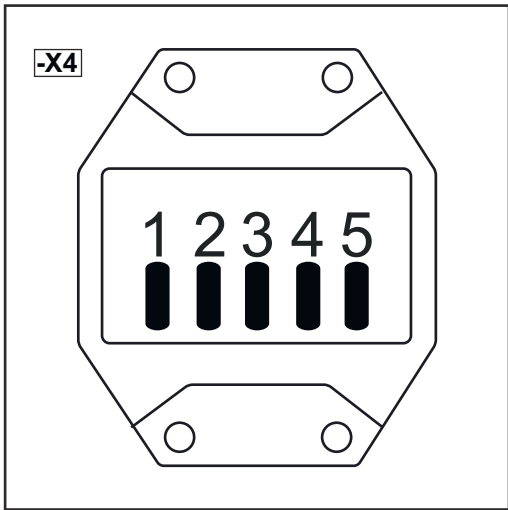

Pin	Assignment
1	+24 V power supply for the fieldbus coupler
2	0 V power supply for the fieldbus coupler
3	+24 V power supply for the I/O terminals
4	0 V power supply for the I/O terminals
5	-

Separate/common 24 V power supply

Separate 24 V power supply

The robot interface Robacta FB 8I_80 is designed as standard for a separate 24 V supply of fieldbus bus coupler and I/O terminals. This requires two separate 24 V circuits, the robot interface does not have to be opened.

Procedure:

- 1 Apply circuit 1 to pins 1 (-X4:1) and 2 (-X4:2)
 - 2 Apply circuit 2 to pins 2 (-X4:3) and (-X4:4)
-

Common 24 V external power supply

Alternatively, fieldbus bus couplers and I/O terminals can also be supplied jointly via a 24 V circuit.

For the external common power supply, the robot interface does not have to be opened.

Procedure:

- 1 On the supplied connector, bridge pin 1 (-X4:1) and pin 3 (-X4:3) with a piece of wire
 - 2 On the supplied connector, bridge pin 2 (-X4:2) and pin 4 (-X4:4) with a piece of wire
 - 3 Apply the circuit to pins 1 (-X4:1) and 2 (-X4:2)
-

Common 24 V internal power supply

The second alternative for a common power supply with a 24 V circuit is the internal power supply.

Procedure:



- 1 Open the robot interface Robacta FB 8I_80
- 2 Disconnect the connector of the fieldbus coupler from 24V/0V

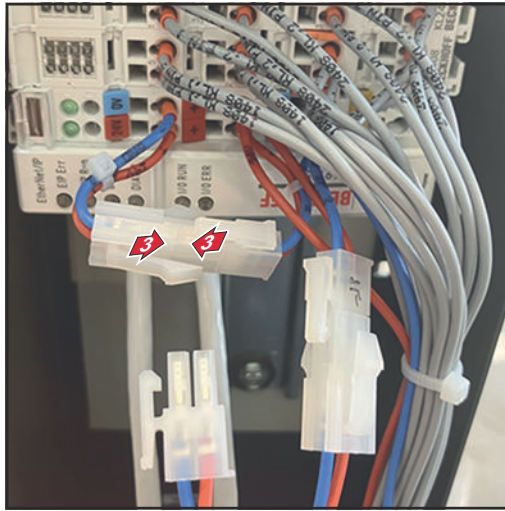

- 3 Connect the 24V/OV cable from the fieldbus coupler to the free cable end of +/-
- 4 Close the robot interface Robacta FB 8I_8O
- 5 Apply circuit to pins 3 (-X4:3) and 4 (-X4:4)

Robacta CTC input and output signals

Arrangement of the fieldbus terminals (optional configuration)

The following shows the fieldbus terminal allocation as set in the factory:

BK 9103	KL1408	KL2408	KL1408 (OPT/i Robacta FB 16L_16O 4,101,345,CK)	KL2408 (OPT/i Robacta FB 16L_16O 4,101,345,CK)	KL9010
---------	--------	--------	--	--	--------

It is possible to install the two fieldbus terminals listed below in the robot interface. This means that a welding torch cleaning device can be connected to the interface in addition to Robacta CTC. For more information on this, see section [Additional scope of functions of Robacta FB 8I_8O Profinet](#) from page 39.

Optional fieldbus terminals

- KL1408 and
- KL2408

Both terminals are part of option 4,101,345,CK.

Input signals (from CTC to robot)

Input	Signal	Range	Activity
E01	TLC	-	High
E02	VA	-	High
E03	LS	-	High
E04	Reserve	-	-
E05	SS1	-	High
E06	SS2	-	High
E07	1A	-	High
E08	Reserve	-	-

Output signals (from robot to CTC)

Output	Signal	Range	Action
A01	MC	-	High
A02	FWD	-	High
A03	REV	-	High
A04	TL	-	High
A05	MO	-	High
A06	M1	-	High
A07	Reserve	-	-
A08	Reserve	-	-

Descriptions of the signals can be found in the Operating Instructions for Robacta CTC.

Additional scope of functions of Robacta FB 8I_80 Profinet

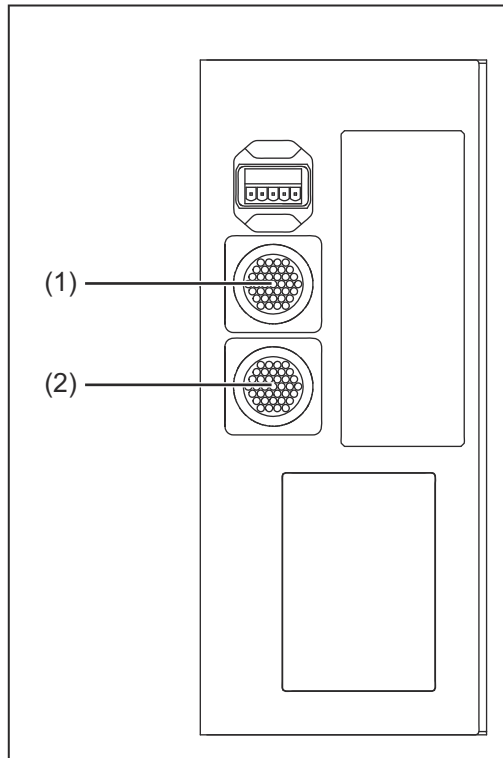

Connections to Robacta FB 8I_80 Profinet

(1) Standard I/O 1 connecting plug

This connecting plug is always found on the robot interface and is used to connect Robacta CTC to the robot interface

(2) Standard I/O 2 connecting plug

This connecting plug is installed in the robot interface with option 4,101,345,CK.

This plug can be used to connect welding torch cleaning devices to the robot interface in addition to Robacta CTC. Only use the cable harnesses available from Fronius to connect the welding torch cleaning devices to the robot interface.

Input signals

for Robacta Reamer V Easy, Robacta Reamer V Easy Han6P J, Robacta Reamer Alu Edition, Robacta Reamer Alu 3000upm, Robacta Reamer Alu brush head, Robacta Reamer Twin:

Input (from the fieldbus coupler to the standard I/O 2 connecting plug)	Pin on the standard I/O 2 connecting plug	Signal	Action
E09	11	Gas nozzle free	High
E10	12	Reserve	-
E11	13	Reserve	-
E12	14	Reserve	-
E13	15	Reserve	-
E14	16	Reserve	-
E15	17	Reserve	-
E16	18	Reserve	-

Output signals for

Robacta Reamer V Easy, Robacta Reamer V Easy Han6P J, Robacta Reamer Alu Edition, Robacta Reamer Alu 3000upm, Robacta Reamer Alu brush head, Robacta Reamer Twin:

Output (from the standard I/O 2 connecting plug to the fieldbus coupler)	Pin on the standard I/O 2 connecting plug	Signal	Action
+24 V	1	-	-
GND	2	-	-
A09	3	Start cleaning	High
A10	4	Reserve	-
A11	5	Reserve	-
A12	6	Reserve	-
A13	7	Reserve	-
A14	8	Reserve	-
A15	9	Reserve	-
A16	10	Reserve	-

Input signals for Reamer Braze+:

Input (from the fieldbus coupler to the stan- dard I/O 2 connec- ting plug)	Pin on the standard I/O 2 connecting plug	Signal	Action
E09	11	Ready for cleaning	High
E10	12	Reserve	-
E11	13	Reserve	-
E12	14	Reserve	-
E13	15	Reserve	-
E14	16	Reserve	-
E15	17	Reserve	-
E16	18	Reserve	-

Output signals for Robacta Reamer Braze+:

Output (from the standard I/O 2 connecting plug to the fieldbus coupler)	Pin on the standard I/O 2 connecting plug	Signal	Action
+24 V	1	-	-
GND	2	-	-
A09	3	Start cleaning motor	High
A10	4	Calibrate cleaning head	High
A11	5	Reserve	-
A12	6	Reserve	-
A13	7	Reserve	-

Output (from the standard I/O 2 connecting plug to the fieldbus coupler)	Pin on the standard I/O 2 connecting plug	Signal	Action
A14	8	Reserve	-
A15	9	Reserve	-
A16	10	Reserve	-

Input signals for Robacta Reamer V:

Input (from the fieldbus coupler to the standard I/O 2 connecting plug)	Pin on the standard I/O 2 connecting plug	Signal	Action
E09	11	Gas nozzle free	High
E10	12	Gas nozzle clamped	High
E11	13	Cleaning motor turns	High
E12	14	Parting agent level OK	High
E13	15	Cleaning motor bottom	High
E14	16	Cleaning motor top	High
E15	17	Wire cutter open	High
E16	18	Wire cutter closed	High

Output signals for Robacta Reamer V:

Output (from the standard I/O 2 connecting plug to the fieldbus coupler)	Pin on the standard I/O 2 connecting plug	Signal	Action
+24 V	1	-	-
GND	2	-	-
A09	3	Clamp gas nozzle/cleaning motor on	High
A10	4	Spray parting agent	High
A11	5	Cut the wire electrode	High
A12	6	Cleaning motor up	High
A13	7	Optional GND for sensors	High
A14	8	Reserve	-
A15	9	Reserve	-
A16	10	Reserve	-

Input signals for Robacta Reamer V Twin:

Input (from the fieldbus coupler to the standard I/O 2 connecting plug)	Pin on the standard I/O 2 connecting plug	Signal	Action
E09	11	Gas nozzle free	High
E10	12	Gas nozzle clamped	High
E11	13	Reserve	-
E12	14	Parting agent level OK	High
E13	15	Cleaning motor bottom	High
E14	16	Cleaning motor top	High
E15	17	Swivel device left	High
E16	18	Swivel device right	High

Output signals for Robacta Reamer V Twin:

Output (from the standard I/O 2 connecting plug to the fieldbus coupler)	Pin on the standard I/O 2 connecting plug	Signal	Action
+24 V	1	-	-
GND	2	-	-
A09	3	Clamp gas nozzle/cleaning motor on	High
A10	4	Spray parting agent	High
A11	5	Cut the wire electrode	High
A12	6	Cleaning motor up	High
A13	7	Swivel device to the left	High
A14	8	Swivel device to the right	High
A15	9	Reserve	-
A16	10	Reserve	-

Input signals for Robacta Reamer V 70 Han12P:

Input (from the fieldbus coupler to the standard I/O 2 connecting plug)	Pin on the standard I/O 2 connecting plug	Signal	Action
E09	11	Gas nozzle free	High
E10	12	Reserve	-
E11	13	Reserve	-
E12	14	Reserve	-
E13	15	Reserve	-
E14	16	Cleaning motor top	High
E15	17	Reserve	-

Input (from the fieldbus coupler to the standard I/O 2 connecting plug)	Pin on the standard I/O 2 connecting plug	Signal	Action
E16	18	Reserve	-

Output signals for Robacta Reamer V 70 Han12P:

Output (from the standard I/O 2 connecting plug to the fieldbus coupler)	Pin on the standard I/O 2 connecting plug	Signal	Action
+24 V	1	-	-
GND	2	-	-
A09	3	Start cleaning	High
A10	4	Spray parting agent	High
A11	5	Cut the wire electrode	High
A12	6	GND for sensors	High
A13	7	Reserve	-
A14	8	Reserve	-
A15	9	Reserve	-
A16	10	Reserve	-

Input signals for Robacta Reamer V Comfort:

Input (from the fieldbus coupler to the standard I/O 2 connecting plug)	Pin on the standard I/O 2 connecting plug	Signal	Action
E09	11	Gas nozzle free	High
E10	12	Output signal sensor	High
E11	13	Output signal sensor	High
E12	14	Parting agent level OK	-
E13	15	Reserve	-
E14	16	Cleaning motor top	High
E15	17	Reserve	-
E16	18	Reserve	-

Output signals for Robacta Reamer V Comfort:

Output (from the standard I/O 2 connecting plug to the fieldbus coupler)	Pin on the standard I/O 2 connecting plug	Signal	Action
+24 V	1	-	-
GND	2	-	-
A09	3	Start cleaning	High
A10	4	Spray parting agent	High
A11	5	Cut the wire electrode	High
A12	6	Actuator output signal	High
A13	7	GND for the sensors	High
A14	8	Reserve	-
A15	9	Reserve	-
A16	10	Reserve	-

Input signals for Robacta TC 1000, Robacta TC 2000:

Input (from the fieldbus coupler to the stan- dard I/O 2 connec- ting plug)	Pin on the standard I/O 2 connecting plug	Signal	Action
E09	11	Ready	High
E10	12	Fluid Level Control	High
E11	13	Cleaning Error	High
E12	14	Reserve	-
E13	15	Reserve	-
E14	16	Reserve	-
E15	17	Reserve	-
E16	18	Reserve	-

Output signals for Robacta TC 1000, Robacta TC 2000:

Output (from the standard I/O 2 connecting plug to the fieldbus coupler)	Pin on the standard I/O 2 connecting plug	Signal	Action
+24 V	1	-	-
GND	2	-	-
A09	3	Cleaning Start	High
A10	4	Spray In	High
A11	5	Wire Cutter	High
A12	6	Quick Stop	High
A13	7	Reserve	-

Output (from the standard I/O 2 connecting plug to the fieldbus coupler)	Pin on the standard I/O 2 connecting plug	Signal	Action
A14	8	Reserve	-
A15	9	Reserve	-
A16	10	Reserve	-

Robacta TX input and output signals

Fieldbus terminal allocation

The following shows the fieldbus terminal allocation as set in the factory:

BK 9103 Fronius	KL1408	KL1408	KL1408	KL2408	KL2612	KL9010
-----------------	--------	--------	--------	--------	--------	--------

Additional fieldbus terminals can be installed in a robot interface. However, the number is limited by the size of the housing.

NOTE!

The process data frame changes when additional fieldbus terminals are installed.

Input signals (from the torch body change station to the robot)

Input	Signal	Range	Action
E01	Torch body sensor 1	-	High
E02	Torch body sensor 2	-	High
E03	Torch body sensor 3	-	High
E04	Torch body sensor 4	-	High
E05	Torch body sensor 5	-	High
E06	Torch body sensor 6	-	High
E07	Torch body sensor 7	-	High
E08	Torch body sensor 8	-	High
E09	Torch body sensor 9	-	High
E10	Torch body sensor 10	-	High
E11	Wire sensor signal	-	High
E12	Pressure switch signal	-	High
E13	Gas nozzle free (with Robacta Reamer V) TC Ready (with Robacta TC)	-	High
E14	Gas nozzle free (with Robacta Reamer V Easy) Cleaning motor bottom (with Robacta Reamer Alu brush head)	-	High

Input	Signal	Range	Action
E15	Cleaning motor turns (with Robacta Reamer V)	-	High
E16	Parting agent filling level OK (with Robacta Reamer V)	-	High
E17	Cleaning motor bottom (with Robacta Reamer V) Cleaning Error (with Robacta TC)	-	High
E18	Cleaning motor top (with Robacta Reamer V)	-	High
E19	Wire cutter closed	-	High
E20	Wire cutter open	-	High
E21	Chute signal	-	High
E22	'C-Sens. 4' Signal 1	-	High
E23	Robacta TX cover sensor 1	-	High
E24	Robacta TX cover sensor 2	-	High

Descriptions of the signals can be found in the Operating Instructions for Robacta TX.

**Output signals
(from the robot
to the torch body
change station)**

Output	Signal	Range	Action
A01	Clamp gas nozzle and cleaning motor on (with Robacta Reamer V) Start cleaning (with Robacta Reamer V Easy and Robacta Reamer Alu brush head) Cleaning Start (with Robacta TC)	-	High
A02	Inject parting agent (with Robacta Reamer V)	-	High
A03	Cleaning motor up (with Robacta Reamer V)	-	High
A04	Cut the wire electrode	-	High
A05	Robacta TX cover valve 1	-	High
A06	Robacta TX cover valve 2	-	High
A07	'C-Act. 3' Signal 1	-	High
A08	Not used	-	-
A09	Valve 1, welding torch changeo- ver	-	High
A10	Reserve for relay OUT	-	High
A11	Not used	-	-

Output	Signal	Range	Action
A12	Not used	-	-
A13	Not used	-	-
A14	Not used	-	-
A15	Not used	-	-
A16	Not used	-	-

Descriptions of the signals can be found in the Operating Instructions for Robac-ta TX.

Robacta TX 10i input and output signals

Fieldbus terminal allocation

The following shows the fieldbus terminal allocation as set in the factory:

BK 9103 Fronius	KL1408	KL1408	KL1408	KL2408	KL2612	KL9010
-----------------	--------	--------	--------	--------	--------	--------

Additional fieldbus terminals can be installed in a robot interface. However, the number is limited by the size of the housing.

NOTE!

The process data frame changes when additional fieldbus terminals are installed.

Input signals (from the torch body change station to the robot)

Input	Signal	Range	Action
E01	Torch body sensor 1	-	High
E02	Torch body sensor 2	-	High
E03	Torch body sensor 3	-	High
E04	Torch body sensor 4	-	High
E05	Torch body sensor 5	-	High
E06	Torch body sensor 6	-	High
E07	Torch body sensor 7	-	High
E08	Torch body sensor 8	-	High
E09	Torch body sensor 9	-	High
E10	Torch body sensor 10	-	High
E11	Wire sensor signal	-	High
E12	Not used	-	-
E13	Gas nozzle free (with Robacta Reamer V) TC Ready (with Robacta TC)	-	High
E14	Gas nozzle free (with Robacta Reamer V Easy) Cleaning motor bottom (with Robacta Reamer Alu brush head)	-	High

Input	Signal	Range	Action
E15	Cleaning motor turns (with Robacta Reamer V)	-	High
E16	Parting agent filling level OK (with Robacta Reamer V)	-	High
E17	Cleaning motor bottom (with Robacta Reamer V) Cleaning Error (with Robacta TC)	-	High
E18	Cleaning motor top (with Robacta Reamer V)	-	High
E19	Wire cutter closed	-	High
E20	Wire cutter open	-	High
E21	Chute signal	-	High
E22	'C-Sens. 4' Signal 1	-	High
E23	Cover sensor 1	-	High
E24	Cover sensor 2	-	High

Descriptions of the signals can be found in the Operating Instructions for Robacta TX 10i.

**Output signals
(from the robot
to the torch body
change station)**

Output	Signal	Range	Action
A01	Clamp gas nozzle and cleaning motor on (with Robacta Reamer V) Start cleaning (with Robacta Reamer V Easy and Robacta Reamer Alu brush head) Cleaning Start (with Robacta TC)	-	High
A02	Inject parting agent (with Robacta Reamer V)	-	High
A03	Cleaning motor up (with Robacta Reamer V)	-	High
A04	Cut the wire electrode	-	High
A05	Robacta TX cover valve 1	-	High
A06	Robacta TX cover valve 2	-	High
A07	'C-Act. 3' Signal 1	-	High
A08	Not used	-	-
A09	Not used	-	-
A10	Reserve for relay OUT	-	High
A11	Not used	-	-

Output	Signal	Range	Action
A12	Not used	-	-
A13	Not used	-	-
A14	Not used	-	-
A15	Not used	-	-
A16	Not used	-	-

Descriptions of the signals can be found in the Operating Instructions for Robac-ta TX 10i.

Robacta TX /i TWIN input and output signals

Fieldbus terminal allocation

The following shows the fieldbus terminal allocation as set in the factory:

BK 9103 Fronius	KL1408	KL1408	KL1408	KL2408	KL2612	KL9010
-----------------	--------	--------	--------	--------	--------	--------

Additional fieldbus terminals can be installed in a robot interface. However, the number is limited by the size of the housing.

NOTE!

The process data frame changes when additional fieldbus terminals are installed.

Input signals (from the torch body change station to the robot)

Input	Signal	Range	Action
E01	Torch body sensor 1	-	High
E02	Torch body sensor 2	-	High
E03	Torch body sensor 3	-	High
E04	Torch body sensor 4	-	High
E05	Torch body sensor 5	-	High
E06	Torch body sensor 6	-	High
E07	Torch body sensor 7	-	High
E08	Torch body sensor 8	-	High
E09	Not used	-	-
E10	Not used	-	-
E11	Wire sensor signal	-	High
E12	Not used	-	-
E13	Gas nozzle free (with Robacta Reamer V Twin) TC Ready (with Robacta TC)	-	High
E14	Not used	-	-
E15	Not used	-	-
E16	Fluid Level Control (with Robacta TC)	-	High
E17	Cleaning Error (with Robacta TC)	-	High

Input	Signal	Range	Action
E18	Not used	-	-
E19	Not used	-	-
E20	Not used	-	-
E21	Not used	-	-
E22	Not used	-	-
E23	Sensor first Robacta TX cover	-	High
E24	Sensor second Robacta TX cover	-	High

Descriptions of the signals can be found in the Operating Instructions for Robacta TX/i TWIN.

**Output signals
(from the robot
to the torch body
change station)**

Output	Signal	Range	Action
A01	Start cleaning (with Robacta Reamer V Twin) Cleaning Start (with Robacta TC)	-	High
A02	Spray In (with Robacta TC)	-	High
A03	Not used	-	-
A04	Cut the wire electrode	-	High
A05	Valve first Robacta TX cover	-	High
A06	Valve second Robacta TX cover	-	High
A07	Not used	-	-
A08	Not used	-	-
A09	Not used	-	-
A10	Reserve for relay OUT	-	High
A11	Not used	-	-
A12	Not used	-	-
A13	Not used	-	-
A14	Not used	-	-
A15	Not used	-	-
A16	Not used	-	-

Descriptions of the signals can be found in the Operating Instructions for Robacta TX/i TWIN.

Troubleshooting

General

CAUTION!

Danger due to voltage when disconnecting or connecting bus terminal contacts.

This can result in damage to property.

- ▶ Before disconnecting or connecting bus terminal contacts, disconnect the mains power.

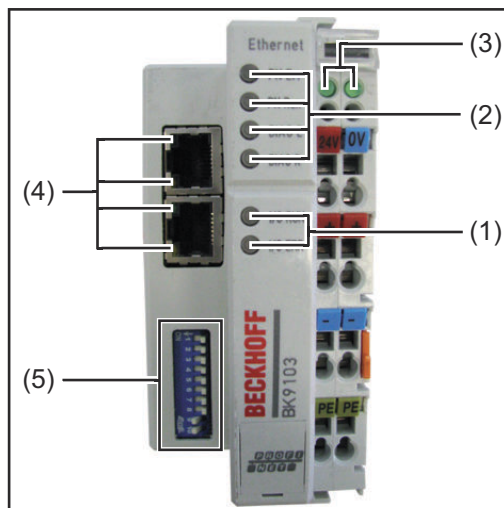

	Description
(1)	Operating status LEDs (indicate the type of fault and the fault location)
(2)	Fieldbus status LEDs (indicate the type of error and the error location)
(3)	Supply display LEDs <ul style="list-style-type: none"> - The left LED shows the supply to the fieldbus coupler - The right LED shows the supply to the power contacts
(4)	Ethernet/Switch diagnostic LEDs
(5)	Dip switch

NOTE!

After the error has been corrected, the fieldbus coupler does not change the flashing sequence in many cases.

The supply voltage should be turned off/on or a software reset should be used to restart the fieldbus coupler.

Fieldbus status LEDs

Ethernet/IP diagnosis	PN Err (red)	PN Run (green)	DIAG E (red)	DIAG R (green)
IP Address OK	Off	0.5 s	Off	Off
Not a valid IP address (DIP switches 9 and 10 turned to 'ON')	0.1 s	Off	Off	Off
Online	Off	On	Off	Off
Offline PLC stop	Off	0.1 s	Off	Off
Timeout	0.5 s	Off	Off	Off

Ethernet/IP diagnosis	PN Err (red)	PN Run (green)	DIAG E (red)	DIAG R (green)
IP address configuration error	On	Off	Off	Off
Flashing in alternation (triggered by a Profinet tool)	0.5 s	0.5 s	Off	Off

Configuration diagnosis	PN Err (red)	PN Run (green)	DIAG E (red)	DIAG R (green)
OK	Off	Off	Off	On
Incorrect module	Off	Off	Slot number	1 x
Missing module (physical)	Off	Off	Slot number	2 x
Missing module (in the configuration)	Off	Off	Slot number	3 x
No Profinet name assigned	Off	Off	Off	4 x
Substitute*	Off	Off	Slot number	5 x

* A substitute is set for modules that are configured incorrectly but still operational (example: KL2xx2 configured, but a KL2xx4 is inserted in the slot instead)

NOTE!

If several errors occur, the last faulty module is always displayed.

Error display example

A KL2xx4 terminal is configured for the fifth slot, but only 4 modules are inserted. The error is displayed as follows:

1. LED DIAG E flashes quickly, LED DIAG R is off
2. LED DIAG E is on, LED DIAG R displays the error code - flashing 2 x for 0.5 seconds
3. LED DIAG E and LED DIAG R are off
4. LED DIAG E displays the reason for the error - flashing 5 x for 0.5 seconds (slot number in this case), LED DIAG R is off

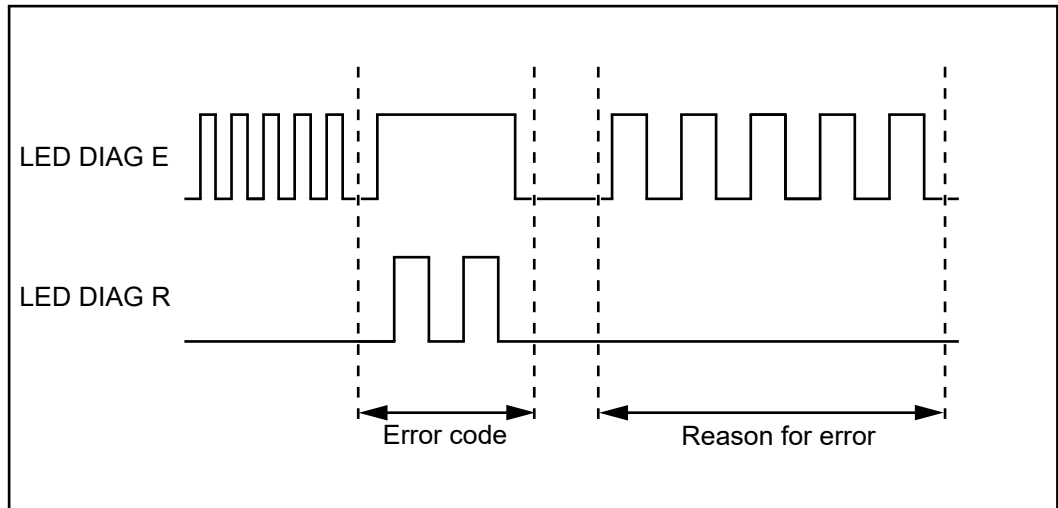

Error display

Operating status LEDs

Error code	Reason for error	Cause	Remedy
Steady, constant flashing	-	EMC problems	<ul style="list-style-type: none"> - Check power supply for under- or over-voltage peaks - Take EMC measures - If this is a communication bus error, localize the error by turning the bus coupler off/on
1 pulse	0 pulses	EPROM checksum error	Reset factory settings using the KS2000 configuration software
	1 pulse	Overflow in code buffer	Insert fewer bus terminals. Too many entries in the table for the programmed configuration
	2 pulses	Unknown data type	Software update of the bus coupler
2 pulses	0 pulses	Programmed configuration, incorrect table entry	Check that programmed configuration is correct
	n pulses (n>0)	Table comparison (bus terminal n)	Incorrect table entry

Error code	Reason for error	Cause	Remedy
3 pulses	0 pulses	Communication bus command error	<ul style="list-style-type: none"> - No bus terminal inserted - One of the bus terminals is faulty, remove half of the inserted bus terminals and check whether or not there is still an error with the remaining bus terminals. Repeat the process until you locate the faulty bus terminal.
4 pulses	0 pulses	Communication bus data error, break behind the bus coupler	Check whether or not the n+1 bus terminal is inserted correctly, replace if necessary
	n pulses	Break behind bus terminal n	Check whether or not the 9010 bus terminal is inserted
5 pulses	n pulses	Communication bus error during register communication with bus terminal n	Replace nth bus terminal
6 pulses	0 pulses	Initialization error	Replace bus coupler
	1 pulse	Internal data error	Turn bus coupler off/on
	4 pulses	DIP switch incorrect for BootP	Set 1-8 to the -Off- position
	8 pulses	Internal data error	Turn bus coupler off/on
14 pulses	16 pulses	IP socket error	Turn bus coupler off/on
	n pulses	nth bus terminal has an incorrect format	Restart bus coupler. If the error reoccurs, replace the bus terminal.
15 pulses	n pulses	Number of bus terminals no longer matches	Restart bus coupler. If the error reoccurs, reset the factory settings using the KS2000 configuration software.
16 pulses	n pulses	Length of communication bus data no longer matches	Restart bus coupler. If the error reoccurs, reset the factory settings using the KS2000 configuration software.

Supply display LEDs

LED	Meaning
Left LED off	No power to bus coupler
Right LED off	No + 24 V _{DC} power supply connected to the power contacts

Ethernet/Switch diagnostic LEDs

LED	On	Flashing	Off
Link/Act	Physical connection available	Communication available	No physical connection available
10 / 100 MBaud	100 MBaud	-	100 MBaud



Fronius International GmbH

Froniusstraße 1
4643 Pettenbach
Austria
contact@fronius.com
www.fronius.com

At www.fronius.com/contact you will find the contact details
of all Fronius subsidiaries and Sales & Service Partners.